

PLANT DATA SHEET

For any enquires please contact
office@civilsydney.com.au

23 Channel Road
 Mayfield West
 NSW 2304
 Ph. (02) 4058 1800
www.civilsydney.com.au

ABN 15 068 316 432

Make:	Hitachi	Model:	KR50
Year:	2018	Plant ID:	PN051
Plant Description:		Capabilities:	
<p>The Hitachi KR50 is setup for difficult access piling projects. It is ideally suited for rail infrastructure, working off or on embankments or 'up & over' situations where its extended reach can be put to use (working radius of over 4.5m). As it has been fitted with rubber track pads and being ZERO swing can work within a standard traffic lane.</p>		<ul style="list-style-type: none"> • Bored Piles • 400 – 1500mm dia • Drilling Depth of 16m • Working radius up to 4.5m including <ul style="list-style-type: none"> • Blade & Rubber Track Pads 	



PLANT DATA SHEET

For any enquires please contact
office@civilsydney.com.au

23 Channel Road
 Mayfield West
 NSW 2304
 Ph. (02) 4058 1800
www.civilsydney.com.au

ABN 15 068 316 432

Operational Weight:	31,000kg
Traveling Length: (Transport)	12,000mm
Working Length: (Full reach)	6,700mm
Working Width:	2,990mm
Traveling Height: (Transport)	3,100mm
Working Height: (Without lattice)	9,100 to 11,300mm
Aux Winch Capacity:	1,000kg

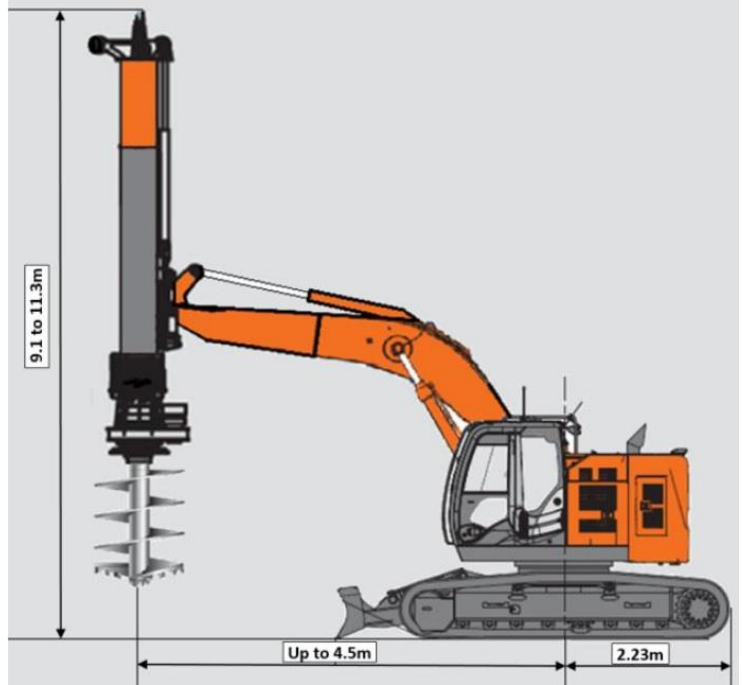

Additional Features:	
Annual 'Pile Safe' & NDT	
Conditional registration	
Rear View Cameras	
On Board Computer	
Service history and plant RA	
Rear View Camera	
E- Stops	
Access Handrails and platforms	
Spill Kits	
Tagged & tested Lifting equipment	

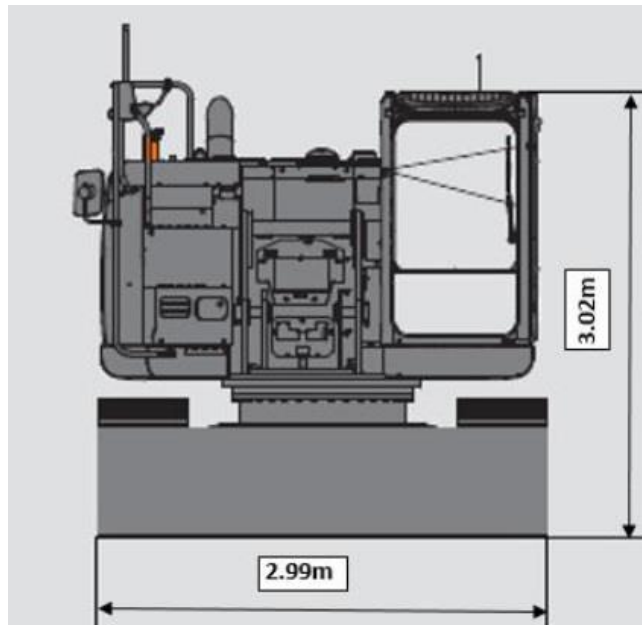

PileSafe®